

Photocell

- use a breadboard for connecting it to your Arduino
- use the *Arduino Serial Monitor* to see the analog input value change depending on the amount of light on the photocell

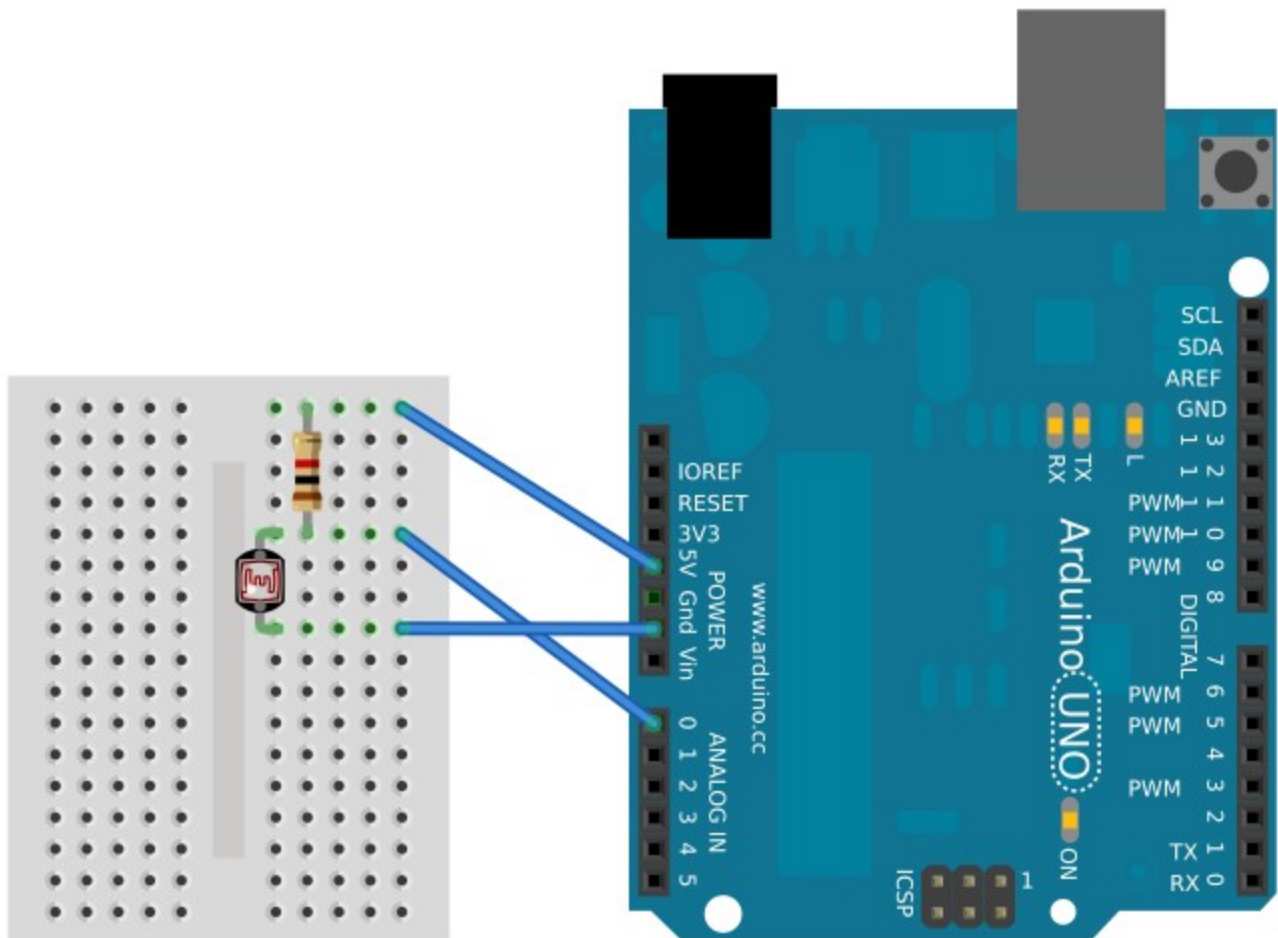

Sample Code: use with Serial Monitor

```
/*
  AnalogReadSerial
  Reads an analog input on pin 0, prints the result to the serial monitor.

  This example code is in the public domain.
  */

void setup() {
    // the setup routine runs once when you press reset:
    // initialize serial communication at 9600 bits per second:
    Serial.begin(9600);
}

void loop() {
    // the loop routine runs over and over again forever:
    // read the input on analog pin 0:
    int sensorValue = analogRead(A0);
    // print out the value you read:
    Serial.println(sensorValue);
    delay(1); // delay in between reads for stability
}
```

Source:

Arduino IDE – File – Examples – Basics - “Analog Read Serial”